



INSTALLATION MANUAL
GRUMPER
PRODUCT NUMBER: GR4400
APPLICATION: 2019 DODGE RAM HD



IMPORTANT SAFETY GUIDE | Your safety and the safety of others is very important.

In order to help you make informed decisions about safety, we have provided the following warnings, safety precautions, installation instructions, and other important information to alert you to potential hazards that could hurt you or others.

Please do a job safety analysis before each task to identify potential hazards for your situation and remove/protect against them. Use own good judgment and take your time.

Check packaged materials immediately upon arrival to ensure that all listed parts are included and undamaged.

Read and understand all warnings, safety precautions, and instructions before installing this product.

SENSORS FIELD OF VIEW WILL BE ALTERED WITH USE OF THE REPLACEMENT BUMPER.

WARNINGS

- Failure to observe the following warnings and instructions provided in this manual could lead to severe injury and/or death.
- For professional installation only. Careless installation and/or operation can result in serious injury, death, and/or equipment damage. All liability for installation and use rests with the user or consumer.
- Fab Fours, Inc. only approves installing this product according to these written instructions with the hardware provided. Failure to install according to these instructions will invalidate the warranty. This includes, but is not limited to, using alternative installation methods, hardware, or materials.
- This product is for off road use only.

SAFETY PRECAUTIONS

- Always remove jewelry and wear eye protection.
- Always use extreme caution when jacking up a vehicle for work. Set emergency brake and use tire blocks. Locate and use the vehicle manufacturers designated lifting points. Use jack stands.
- Always use appropriate and adequate care in lifting components into place.
- Always ensure components will remain secure during installation and operation.
- Always wear safety glasses when installing this kit. A drilling operation will cause flying metal chips. Flying chips can cause serious eye injury.
- Always use extreme caution when drilling a vehicle. Always disconnect power before welding. Thoroughly inspect the area to be drilled (on both sides of material when possible) prior to drilling, and relocate any objects that may be damaged.
- Always use extreme caution when welding a vehicle. Thoroughly inspect the area to be welded (on both sides of material when possible) prior to welding, and relocate any objects that may be a fire hazard. When welding in a cab, make sure the interior surfaces are covered (e.g., welding blanket) and a fire extinguisher is at hand.
- Always use extreme caution when cutting and trimming during fitting.
- Always tighten all nuts and bolts securely per installation instructions.
- Always route electrical cables carefully. Avoid moving parts, components that become hot, and rough or sharp edges.
- Always insulate and protect all exposed wiring and electrical terminals.
- Perform regular inspections and maintenance on mounts and hardware.

TABLE OF CONTENTS

2	SAFETY / DISCLAIMER
3	TABLE OF CONTENTS
4	A MESSAGE FROM THE OWNER
5	GETTING STARTED
6	PROVIDED MATERIAL
8	DISASSEMBLY
14	INSTALLATION
20	CONTACT

A MESSAGE FROM THE OWNER



Fab Fours' was born out of a passion for customizing vehicles and a love for the outdoors. Our engineering team uses the latest 3D design software to turn new product ideas into reality. In our factory, designs come to life with the combination of cutting edge technology for metal cutting and forming and an American workforce that puts its' heart and pride into every product.

From design and manufacturing, to quality and delivery, Fab Fours' mission is to be the market leader for steel truck and jeep accessories. We make sure a quality product is delivered on time, more than expected, better than expected to our customers.

Enjoy your new Fab Fours product. Welcome to the family!

Ereg Higgs

FOUNDER, FAB FOURS

GETTING STARTED

Before you begin the installation process of your new Fab Fours product, we suggest laying out all materials and parts on a pad or protective surface.

Failure to fully account for all components before beginning installation may leave vehicle immobile until part is acquired. Refer to the next pages as an inventory check.



PROVIDED MATERIALS

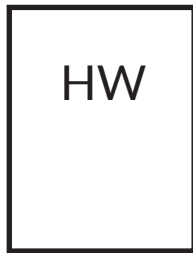

50125-HW

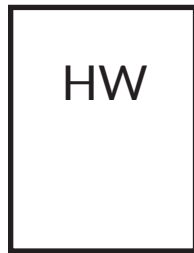

50209-HW



GR4400-IM

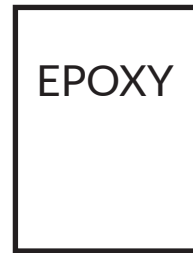

61632
QTY: 3



22044

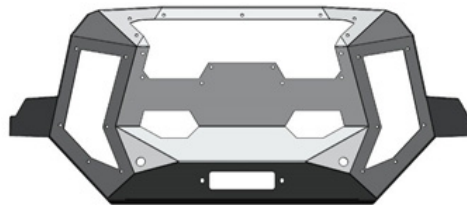

22045



22046



22051

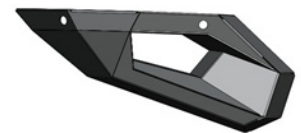

22047



61713

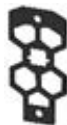

22069

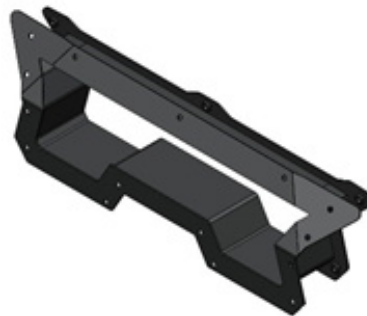

22048



22054
QTY: 2



22052



22053



22049



22050



22055-01



22055-02

HARDWARE KIT | 50209

FAB FOURS IDENTIFICATION	COMPONENT DESCRIPTION	QTY
50209-HW	5/16"-18x1.0" GR8, Yellow-zinc, Hex head cap screw	2
50209-HW	5/16" GR8, Yellow-zinc, Flat washer	4
50209-HW	5/16" GR8, Yellow-zinc, Lock washer	2
50209-HW	5/16" GR8, Yellow-zinc, Hex nut	2
50209-HW	3/8"-16 x 1", GR8, Yellow-zinc, Hex head cap screw	24
50209-HW	3/8" GR8, Yellow-zinc, Lock washer	24
FAB FOURS IDENTIFICATION	COMPONENT DESCRIPTION	QTY
50209-HW	3/8" GR8, Yellow-zinc, Flat washer	30
50209-HW	3/8" GR8, Yellow-zinc, Hex nut	6
50209-HW	7/16"-14 x 1" GR8, Yellow-zinc, Hex head cap screw	8
50209-HW	7/16" GR8, Yellow-zinc, Hex nut	4
50209-HW	7/16" GR8, Yellow-zinc, Flat washer	12
50209-HW	7/16" GR8, Yellow-zinc, Lock washer	8

HARDWARE KIT | 50125

FAB FOURS IDENTIFICATION	COMPONENT DESCRIPTION	QTY
50125-HW	5/16"-18 x 1.0", 18-8, Stainless steel, Button head cap screw	29
50125-HW	5/16"-18, 18-8, Stainless steel, Hex nut	29
50125-HW	5/16", 18-8, Stainless steel, Lock washer	29
50125-HW	5/16" x 3/4"OD, 18-8, Stainless steel, Bonded sealing washer	29
50125-HW	5/16", 18-8, Stainless steel, Flat washer	29
50125-HW	7/16", USS, 18-8, Stainless steel, Flat washer	4
50125-HW	7/16"-14 x 1.5", 18-8, Stainless steel, Button head cap screw	2
50125-HW	7/16"-14, 18-8, Stainless steel, Hex nut	2

TOOLS REQUIRED

- 3/16" Allen wrench
- 1/4" Allen wrench
- 1/2" Open end wrench
- 9/16" Open end wrench
- 5/8" Open end wrench
- 1/2" Socket wrench
- 9/16" Socket wrench
- 11/16" Open end wrench
- 10mm Socket wrench
- 18mm Socket wrench
- T27 Torx bit
- Plastic panel pry tool
- 24mm Socket wrench
- 18mm Open end wrench

ASSISTANCE

We recommend two people perform the installation as items are heavy and may need to be held in place while installing.

ORGANIZATION

Disassemble the vehicle where you can catalog and store everything. We suggest labeling and bagging all the OEM bolts when removing from the vehicle. Failure to keep track of parts could lead to an inability to properly reinstall components.

DISASSEMBLY

Note: Save all OEM parts until installation is complete!

1. Using a plastic panel pry tool, remove the (14) push pins from the under-hood closeout. (Figure 1)

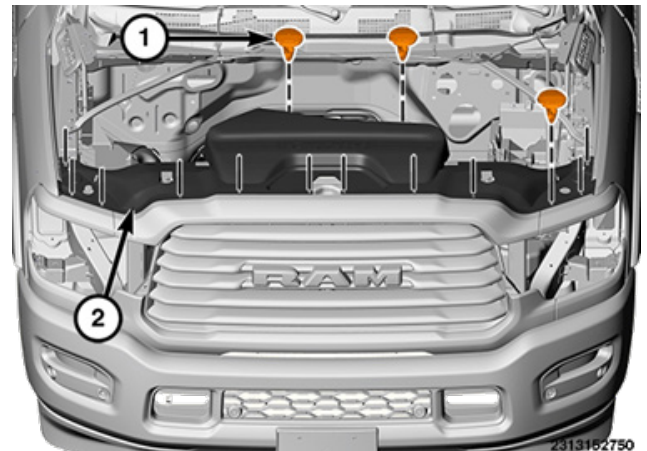

Figure 1

2. Using a 10mm socket wrench and plastic panel pry tool, remove the (10) fasteners and two (2) push pins from the upper valance. (Figure 2)

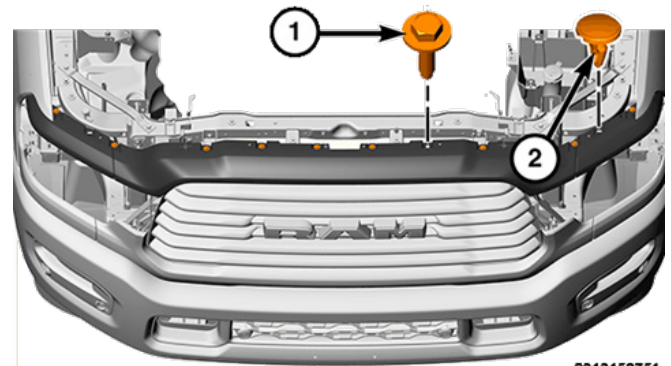

Figure 2

3. Remove the upper valance from the vehicle. (Figure 3)

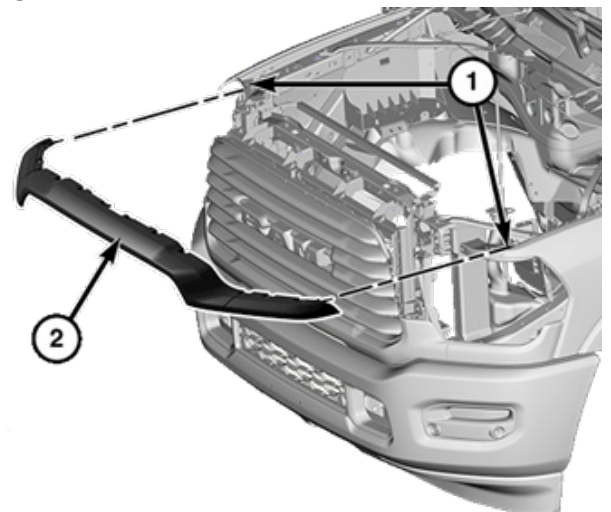
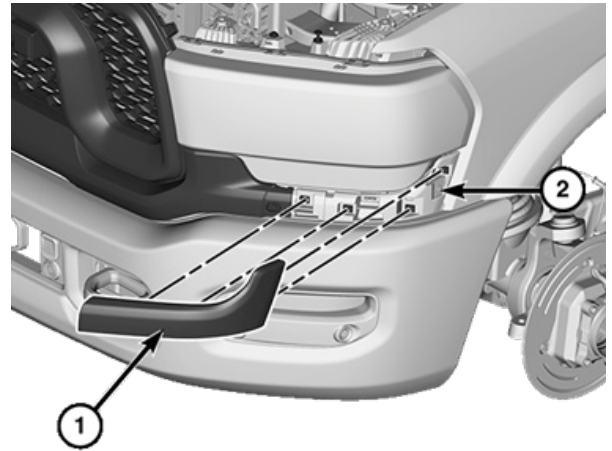

Figure 3

4. Using a plastic body panel pry tool, release the four (4) clips on the driver side headlight valance and remove from the vehicle. (Figure 4)

5. Repeat step 4 on the passenger side of the vehicle



2313152753

Figure 4

6. Using a 10mm socket wrench, remove the two (2) fasteners at each side of the lower valance. (Figure 5)



2313152754

Figure 5

7. Remove the lower valance from the vehicle. (Figure 6)

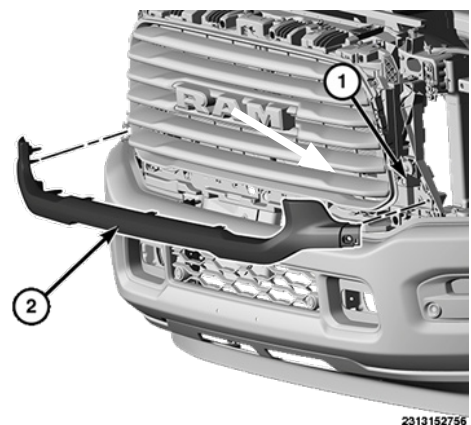

2313152756

Figure 6

8. Using a 10mm socket wrench, remove the four (4) fasteners at the lower outer corners of the grille. (Figure 7)

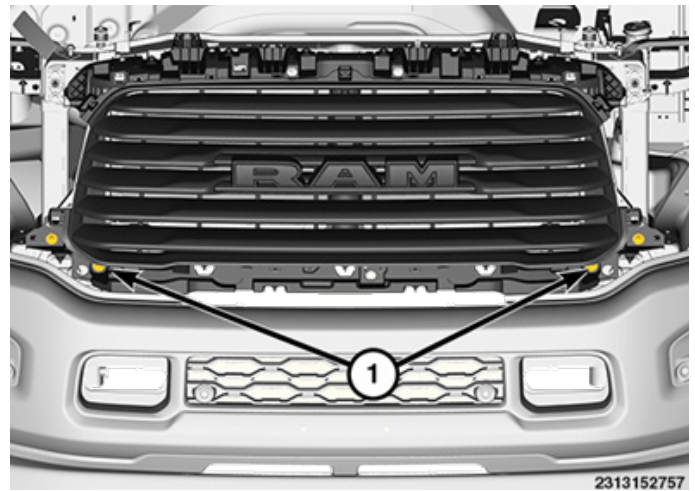

Figure 7

9. Using a 10mm socket wrench, remove the four (4) fasteners from the top of the grille. (Figure 8)

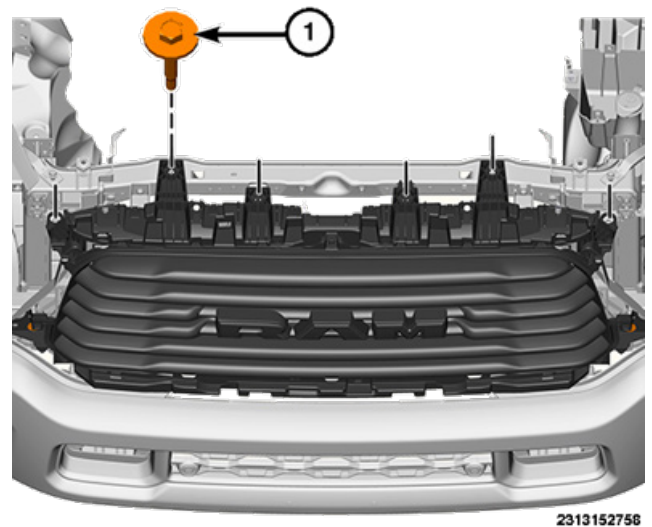

Figure 8

10. Remove the grille from the vehicle. (Figure 9)

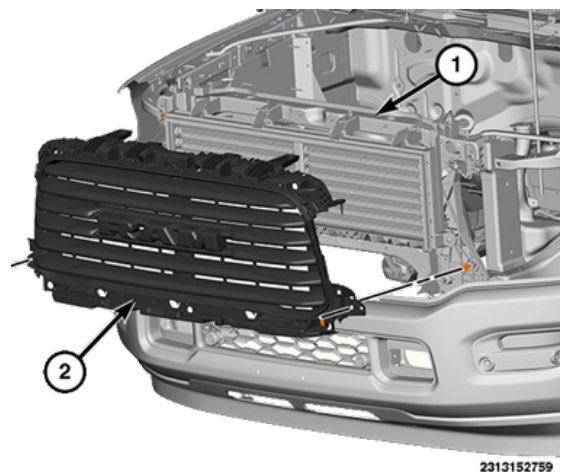
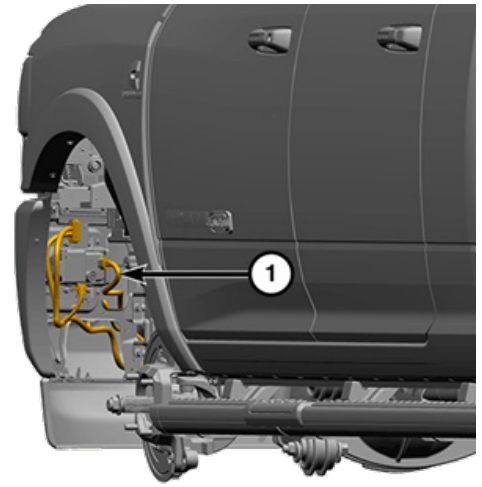

Figure 9

11. Disconnect the electrical harness in the bumper from the vehicle. (Figure 10)



1303149748

Figure 10

12. Using an 18mm socket wrench and open-end wrench, remove the three (3) fasteners per frame rail attaching the bumper to the frame. (Figure 11)

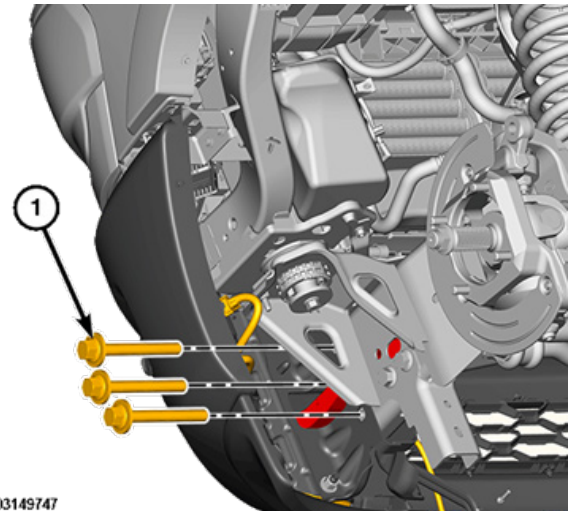

1303149747

Figure 11

**13. Remove the bumper assembly from the vehicle.
(Figure 12)**

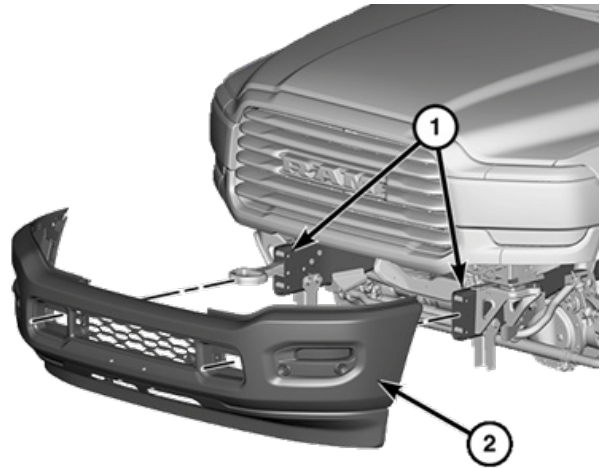

1303149743

Figure 12

14. Using a 24mm socket wrench, remove the fastener holding the tow hook in the frame. Then remove the two (2) fasteners attaching the under-run guards to the frame rails. (Figure 13)



Figure 13

15. Using a plastic body panel pry tool, remove the wiring harness from the OEM bumper by releasing all of the ribbed shank push pins. (Figure 14)

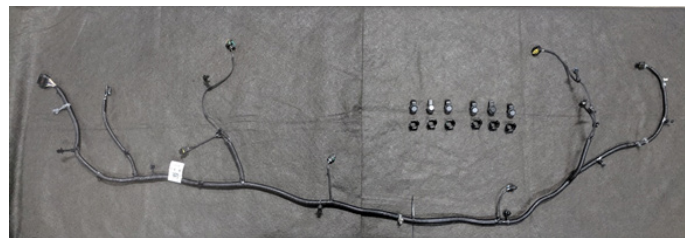

Figure 14

16. Remove the sensors from their housings by spreading the tabs on the housings and pulling up on the sensors. (Figure 15-16)



Figure 15



Figure 16

17. Remove the sensors from their housings by spreading the tabs on the housings and pulling up on the sensors. (Figure 17-18)



Figure 17



Figure 18

INSTALLATION

18. Reinstall the headlight valance pieces removed earlier by reversing the process used to remove them.

19. Using a 3/16" Allen wrench and 1/2" open end wrench, attach the three (3) provided tunnels (22048, 22049, 22050) to the grille shell (22045) with (27) of the provided 5/16", stainless steel button head cap screws, bonded sealing washers, flat washers, lock washers, and nuts (50125-HW). (Figure 19)



Figure 19

20. Using a 9/16", open end wrench, attach the three (3) provided mesh plates (22051, 22052, 22053) to their corresponding tunnels (22048, 22049, 22050) with (18) of the provided 3/8", grade 8, hex head cap screws, flat washers, and lock washers. (50209-HW). The provided camera mounting mesh (22069) can be installed to the center of the upper tunnel mesh (22051) if your vehicle is equipped with a forward-facing camera. (Figure 20-21)

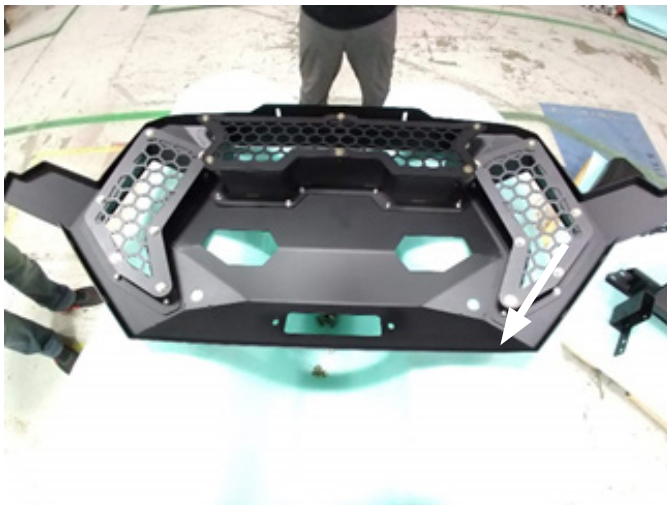

Figure 20



Figure 21

21. If your vehicle is equipped with a forward-facing camera, attach the camera's OEM housing to the provided camera mounting mesh (22069) in the orientation it was removed from the OEM grille using one (1) of the provided epoxy kits (61632). (Figure 22)



Figure 22

22. Using the four (4) OEM fasteners per frame rail removed earlier, installed the provided winch tray (22044) to the frame rails. Leave the fasteners hand tight for now. (Figure 23)

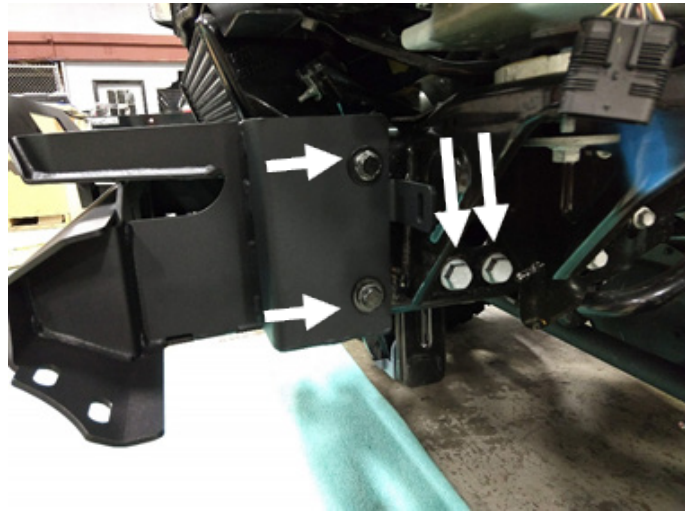

Figure 23

23. If you are installing a winch, do so now per the manufacturer's instructions

24. Using two (2) of the provided 3/8", grade 8, hex head cap screws, flat washers, lock washers, and nuts (50209-HW) loosely install the provided core support mounting brackets. The (Driver side: 22055-01) (Passenger side: 22055-02) (Figure 24)



Figure 24

25. Using two (2) of the provided 7/16", Stainless steel button head cap screws, flat washers, lock washers, and nuts (50125-HW) loosely install the assembled grille section to the winch tray using the slotted holes around the fairlead opening. (Figure 25)



Figure 25

26. Using two (2) of the OEM fasteners removed earlier to loosely attach the core support brackets (22055-01 & 22055-02) to the core support. (Figure 26)



Figure 26

27. Align the grille to the headlights and headlight valances. Using an 18mm open-end, 18mm socket wrench, and 24mm socket wrench, tighten the winch tray to the frame.

28. Using a 1/4" Allen wrench and 11/16" open-end wrench, tighten the fasteners around the fairlead opening.

29. Using a T27 Torx bit, 9/16" open-end wrench, and 9/16" socket wrench, tighten the fasteners previously installed in the core support brackets.

30. Using two (2) of the provided 7/16", grade 8, hex head cap screws, lock washers, and flat washers (50209-HW), loosely install the driver side wing (22046) to the welded in nuts in the winch tray. Then install two (2) of the provided 7/16", grade 8, hex head cap screws, flat washers, lock washers, and nuts (50209-HW) to connect the wing to the grille section. (Figure 27-28)

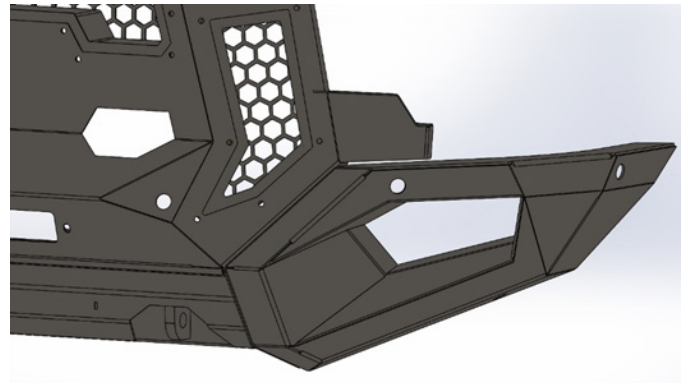

Figure 27

31. Repeat step 27 on the passenger side of the Grumper

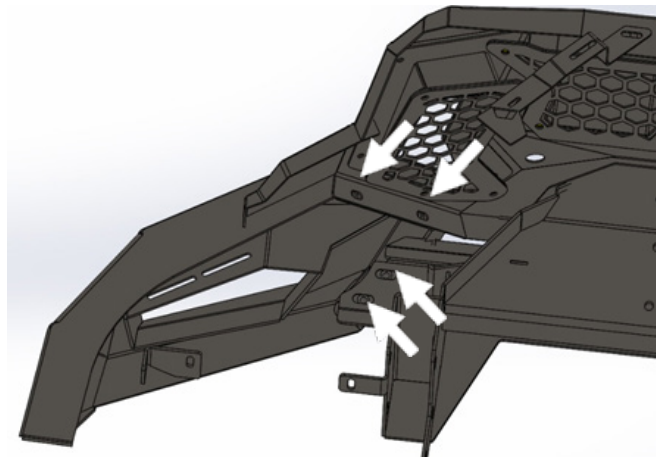

Figure 28

32. Using two (2) of the provided 3/8", grade 8, hex head cap screws, flat washers, lock washers, and nuts (50209-HW) install the provided wing stiffeners (22054) between the wings and the winch tray (22044). (Figure 29)

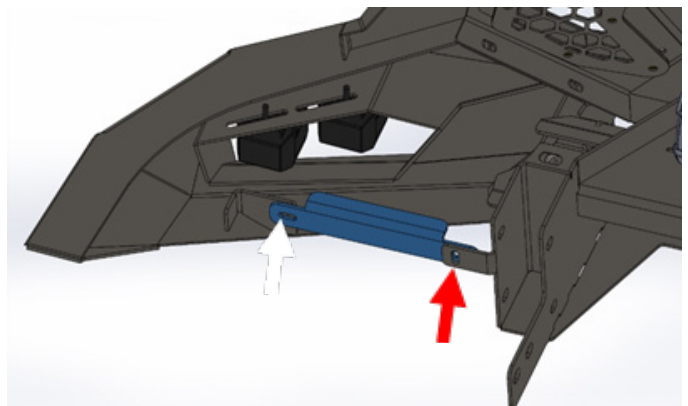

Figure 29

33. Align the wings to the headlight valances keeping a 3/8" clearance to the vehicle. Using a 5/8" open-end wrench and 11/16" open-end wrench to tighten the four (4) 7/16" fasteners in the wings.

34. Using a 9/16" socket wrench and open-end wrench tighten the fasteners on the wing stiffeners.

35. Reinstall the upper valance using the OEM hardware for the outer mounting locations above the headlights. Use two (2) of the provided 5/16", grade 8, hex head cap screws, flat washers, lock washers, and nuts (50209-HW) to attach the center to the core support brackets. (Figure 30)



Figure 30

36. Reinstall the front parking sensors into the holes in the Grumper grille and wings in the orientations and locations they were removed from. Test the sensors and if they are functioning properly, apply a small dab of the provided epoxy (61632) to the sensor housing to affix them to the inside of the Grumper.

37. Install the provided Fab Fours badge to the face of the grille section, centering it between the winch access holes, and upper tunnel. (Figure 31)



Figure 31

Maintenance/Care

- Periodically check and tighten all fasteners.
- Stripped, fractured, or bent bolts or nuts need to be replaced