



I-SHEET NUMBER: INST-00014  
 PART NUMBER: GFF99-CCTX, GFF99-QCTX  
 PRODUCT: Growler Running Board  
 APPLICATION: 99-16 F250/350/450 CC QC

HARDWARE DESCRIPTION		QTY.
HWKT-06123X		
CLIP-00646X	3/8"-16 X 3/4" BARREL NUT CLIP	6
HHCS-00568X	3/8"-16 X 1" GRADE 5 HEX CAP SCREW	6
CARB-00680X	3/8"-16 X 1-1/2" GRADE 5 CARRIAGE BOLT	6
FLHB-00688X	3/8"-16 X 1" GR. 5 HEX SERRATED FLANGE BOLT	6
HXNT-00717X	3/8"-16 GRADE 5 FINISHED HEX NUT	6
FLTW-00663X	3/8" USS FLAT WASHER	12

PARTS INCLUDED	QTY
Running Boards	2
Rocker Panel mounting Brackets	6
Threaded clamp plates	6



# GROWLER

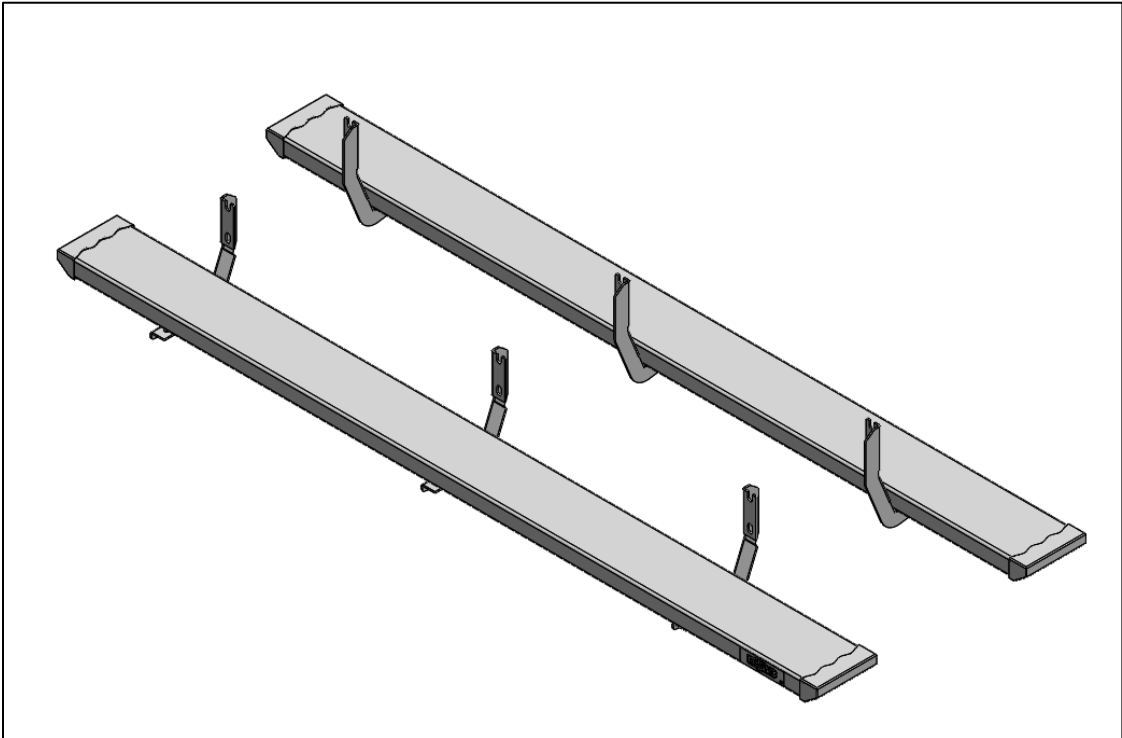

**Step 1** Starting with the Driver side, locate the holes for the upper mounts (x3) and install the supplied (x2) 3/8" clips in each position. **NOTE: There will be four attachment points for the Quad Cab and five for the Crew Cab. Only three will be used for the installation. See below for your cab configuration.**

GFF99-CCTX (Crew Cab)

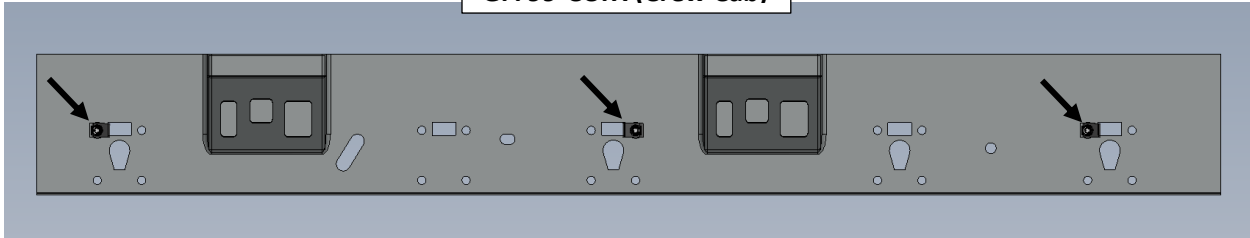

GFF99-QCTX (Quad Cab)

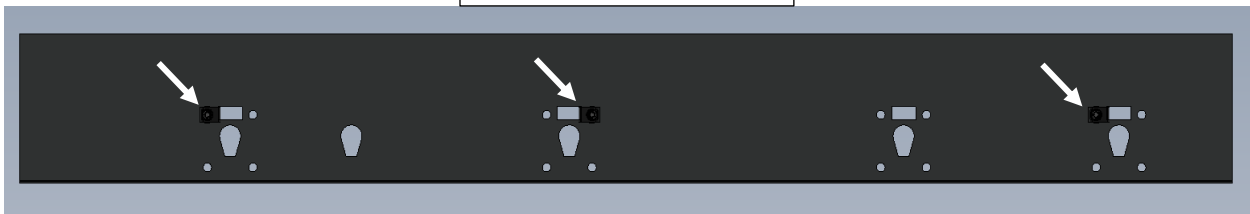

**Step 2** Next, install (x3) of the supplied Rocker panel mounting brackets to the factory mounts using the 3/8"x1" Hex bolt, 3/8" USS Flat washer for the upper attachment and the 3/8"x 1 1/2" carriage bolt 3/8" Hex nut and 3/8" USS washer for the lower attachment. Leave loose for now. **NOTE: The carriage bolts will start from the outside of the body, the nut and washer will be only visible from underneath the vehicle.**

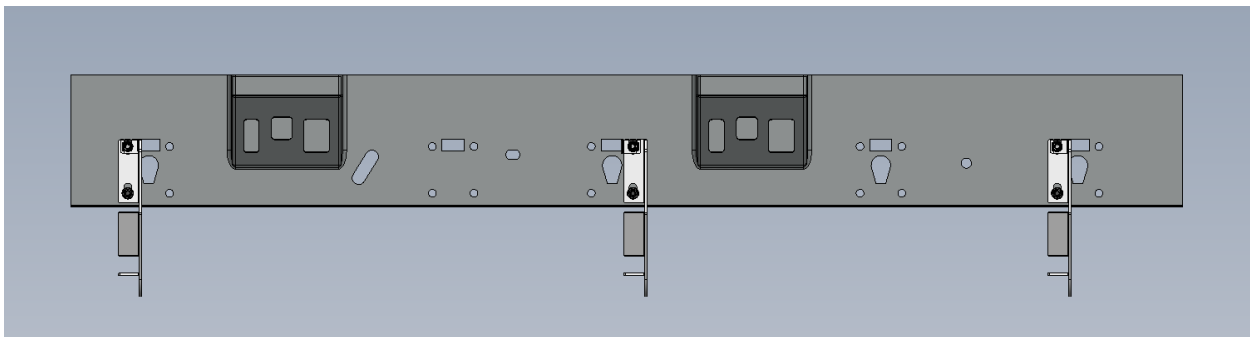

**Step 3:** Insert the supplied threaded brackets (X3) inside the running board lip over the top of each bracket.

**Step 4:** With the supplied 3/8" x 1" hex bolts, secure each mounting location and leave loose.

**Step 5:** After final adjustment, tighten all running board threaded mounts.

**Step 6:** Next, adjust frame brackets so the running board is level with body of the vehicle and tighten all factory-mounting locations.

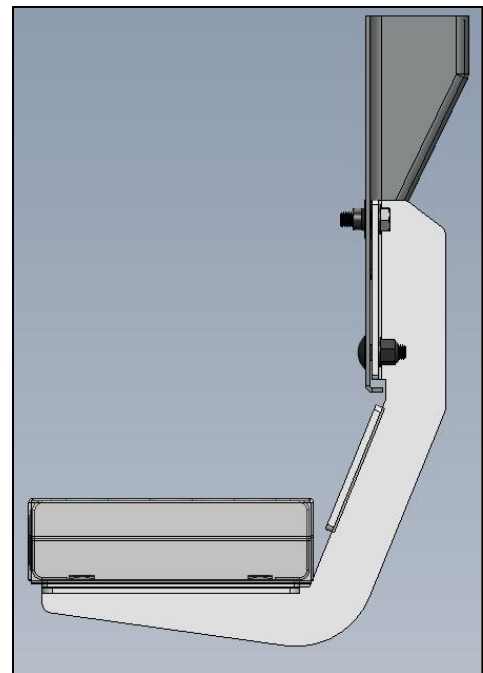
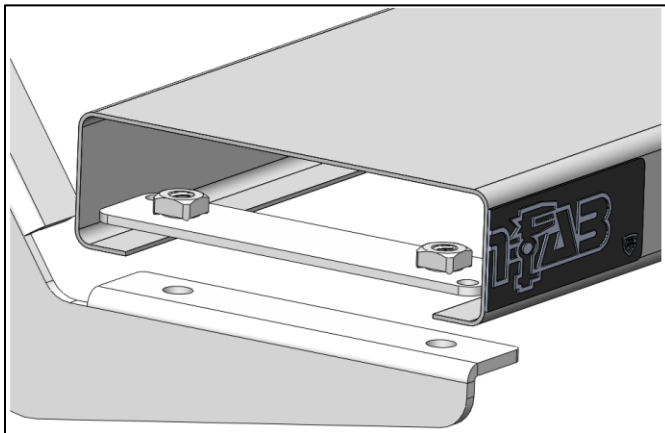

**Step 7:** Repeat steps 1-6 for passenger side.