



n-fab.com

nfabinc f t

I-SHEET NUMBER: INST-00053
 PART NUMBER GFF99RC-TX
 PRODUCT: **Growler Running Board**
 APPLICATION: 99-16 F250/350 Reg. Cab

HARDWARE DESCRIPTION		QTY.
HWKT-06127X		
FLTW-00663X	3/8" USS FLAT WASHER	8
HHCS-00568X	3/8"-16 X 1" GRADE 5 HEX CAP SCREW	4
CLIP-00646X	3/8"-16 X 3/4" BARREL NUT CLIP	4
CARB-00680X	3/8"-16 X 1-1/2" GRADE 5 CARRIAGE BOLT	4
FLHB-00688X	3/8"-16 X 1" GRADE 5 FLANGE BOLT	4
HXNT-00717X	3/8"-16 GRADE 5 FINISHED HEX NUT	4

PARTS INCLUDED	QTY
Running Board	2
Rocker Panel mounting Brackets	4
Threaded clamp plates	4



GROWLER

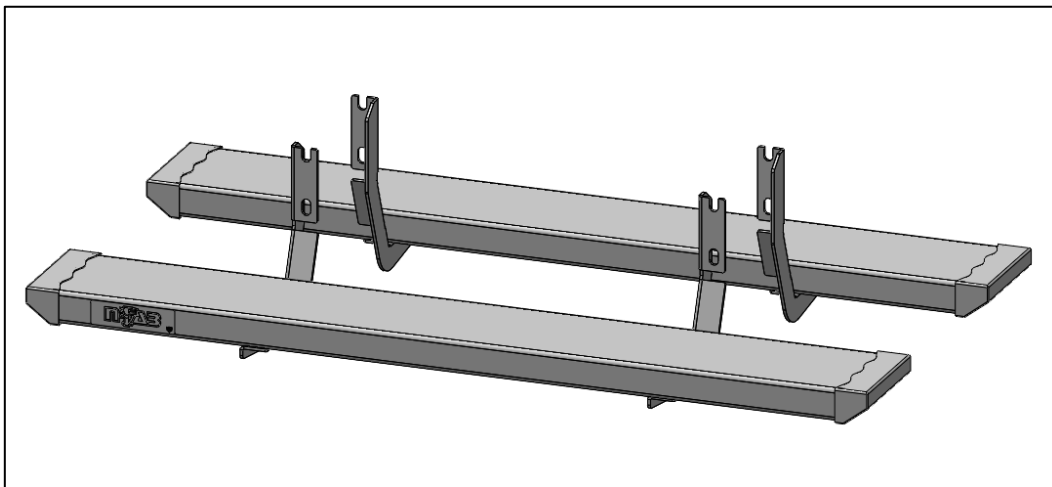

Step 1: Starting with the Driver side, locate the holes for the upper mounts (x2) and install the supplied (x2) 3/8" clips in each position. See below for configuration.

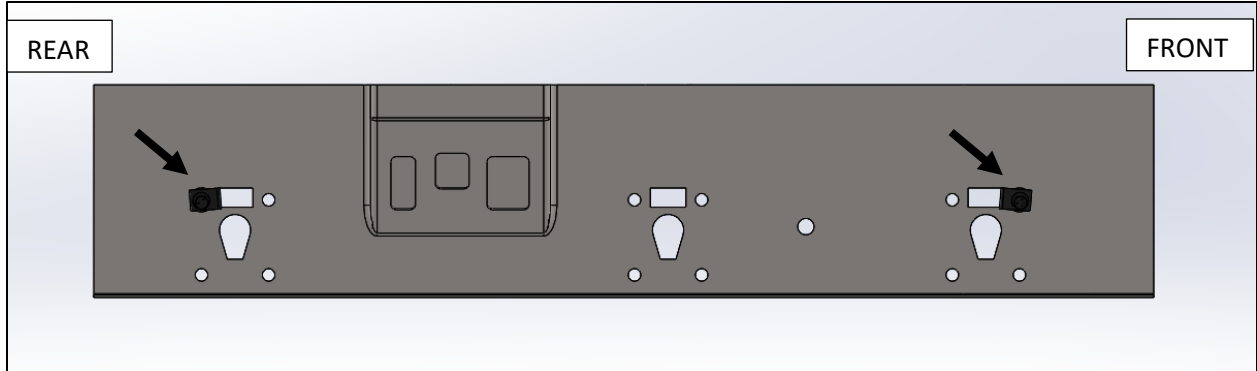

Step 2: Next, install (x2) of the supplied Rocker panel mounting brackets to the factory mounts using the 3/8"x1" Hex bolt, 3/8" USS Flat washer for the upper attachment and the 3/8"x 1 1/2" carriage bolt 3/8" Hex nut and 3/8" USS washer for the lower attachment. Leave loose for now. **NOTE: The carriage bolts will start from the outside of the body, the nut and washer will be only visible from underneath the vehicle.**

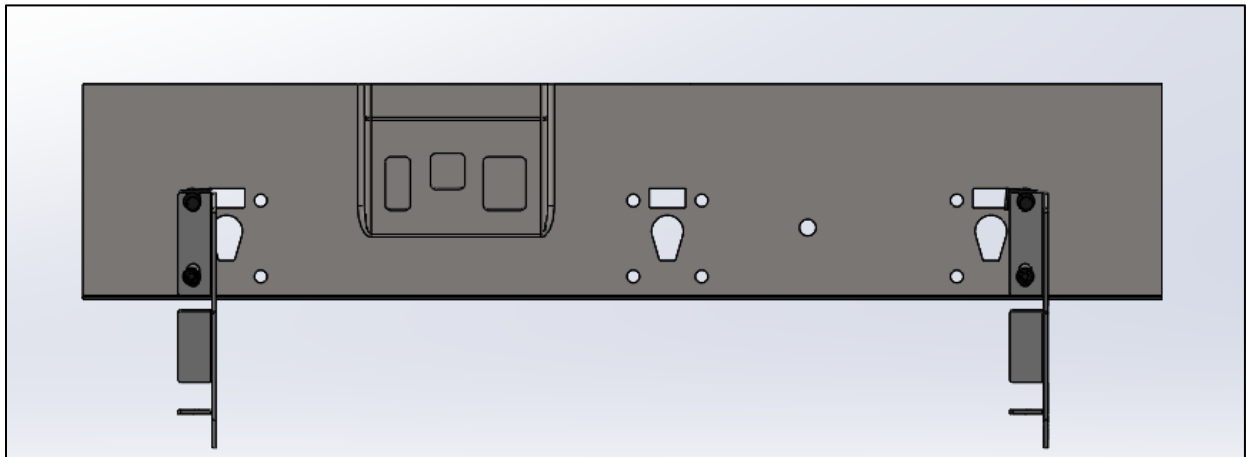



n-fab.com

mfabinc f t

I-SHEET NUMBER: INST-00053

PART NUMBER GFF99RC-TX

PRODUCT: Growler Running Board

APPLICATION: 99-16 F250/350 Reg. Cab

Step 3: Set running board along the top of the two brackets and center along the cab.

Step 4: Insert the supplied threaded brackets (X2) inside the running board lip over the top of each bracket.

Step 5: With the supplied 3/8" x 1" hex bolts, secure each mounting location and leave loose.

Step 6: After final adjustment, tighten all running board threaded mounts.

Step 7: Finally, adjust frame brackets so the running board is level with body of the vehicle and tighten all factory-mounting locations.

