

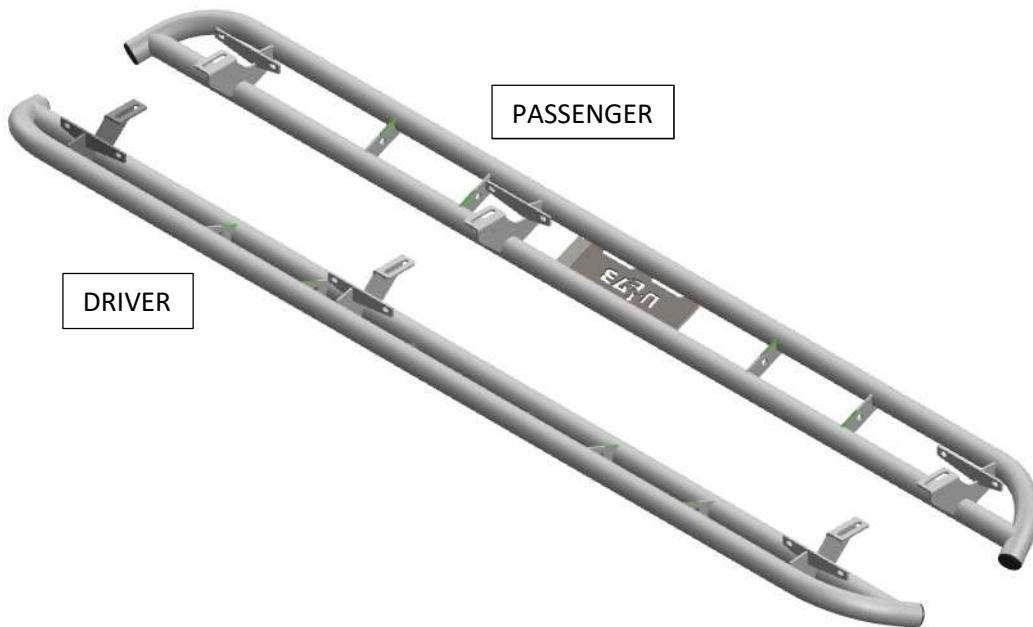

(Shown with optional Part# JPT32 detachable steps)

HARDWARE DESCRIPTION	QTY.
KIT# HWK-00010X	
M8x30mm flanged hex bolt with washer	6
M8x25mm Flanged hex head bolt ( Black zinc)	12
M8 flanged nuts	12

**Step 1.** Identify the driver side step.



**Step 2.** Remove the factory running boards and discard.



**Step 3.** Starting with driver side step; carefully raise up into position and align the brackets with the factory mounting points with the horizontal part of the bracket on the outside of the pinch weld.

**Step 4.** Next, start one of the supplied M8x30mm hex head flanged bolt and washer starting with the center bracket in the factory threaded hole and leave loose.

**Step 5.** Start two M8x25mm black zinc flanged bolts and two M8 flanged nuts in the pinch weld and leave loose for final adjustment.



**Step 6.** Continue installing the rest of the hardware in the remaining brackets and leave loose.

**Step 7.** Adjust the nerf-step where the main bar is level with the body of the vehicle.



**Step 8.** First, tighten all the hardware that attaches the bracket to the pinch weld of the vehicle.



**Step 9.** Next, tighten the remaining hardware that attaches the bracket to the upper body mount.



**Step 10.** Repeat steps 4-9 for the Driver side.

## PRT# JPTS32 Detachable Step Installation.

**Step 1:** Attach the step to the mounts located in between the RKR rails using the supplied 1/2" x 1" flanged hex bolts and 1/2" flanged hex nuts. **NOTE: The step will mount to the left of the bracket opposite of the weld.**

HARDWARE DESCRIPTION	QTY.
3/4"X1" HEX BOLT	8
3/4" HEX FLANGED NUT	8

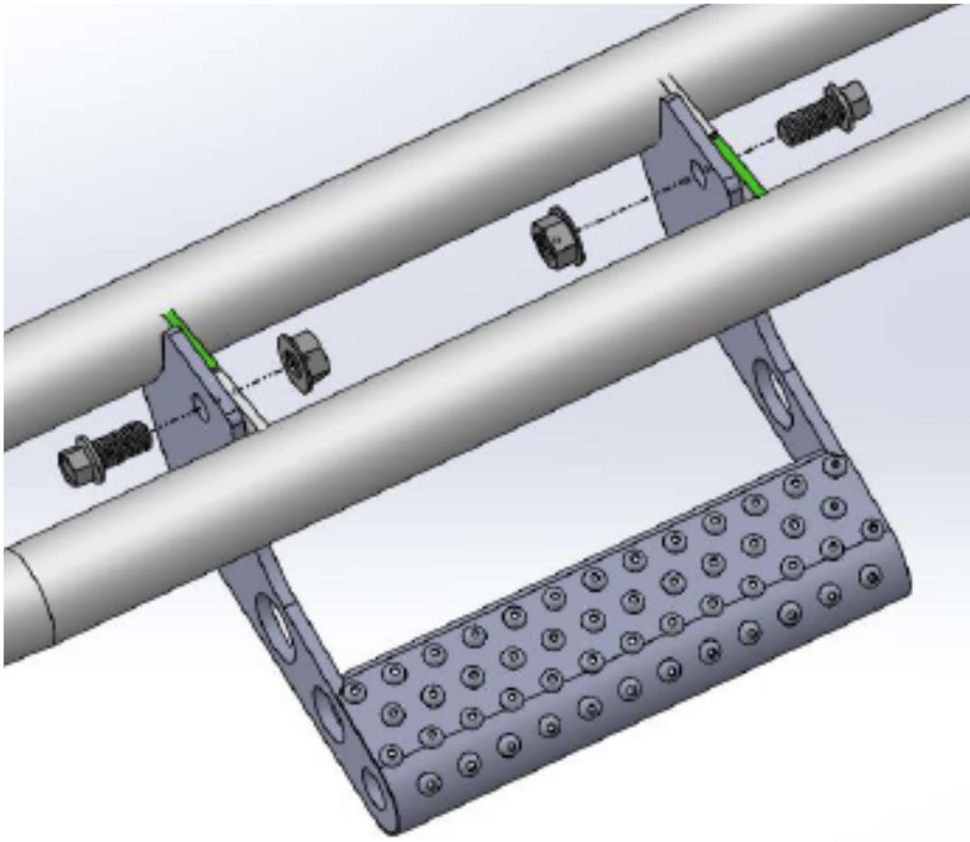

**Step 2:** Torque bolts to a target of 40 ft/lbs. / 54nm