

# Load CONTROLLER I™

by AIR LIFT®

# Kit 25655

## Single Gauge Controller

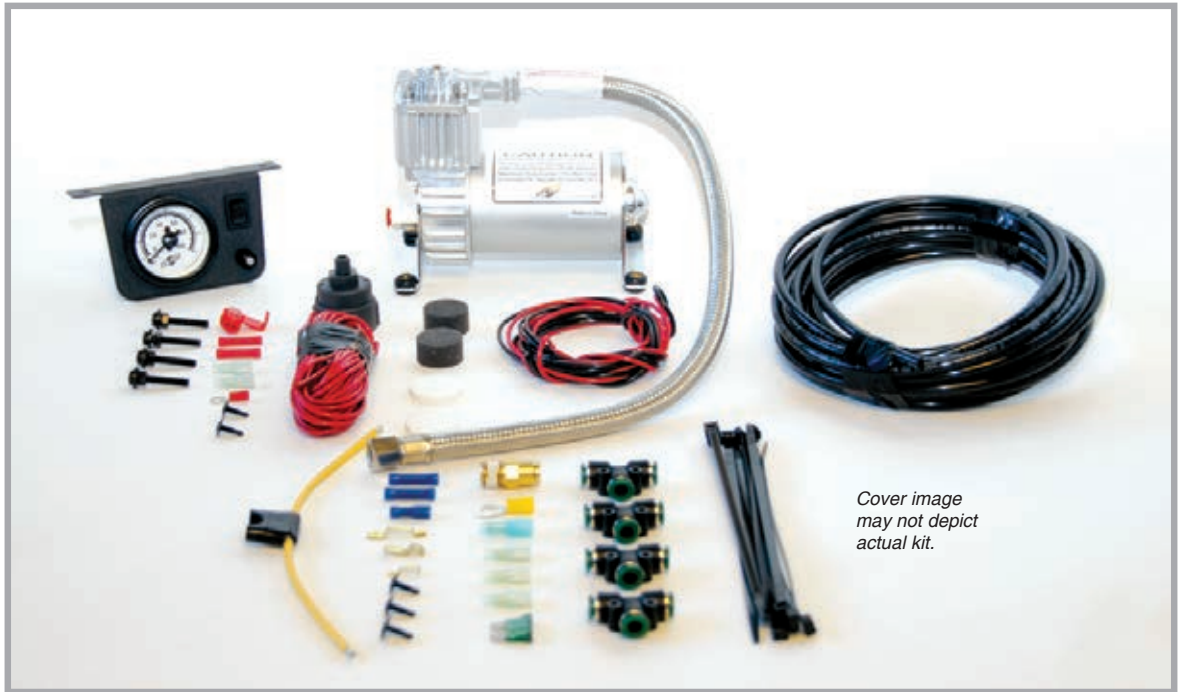

## INSTALLATION GUIDE

For maximum effectiveness and safety, please read these instructions completely before proceeding with installation.

*Failure to read these instructions can result in an incorrect installation.*



# TABLE OF CONTENTS



<b>Introduction</b> .....	<b>2</b>
Important Safety Notice .....	2
Notation Explanation .....	2
<b>Installation Diagram</b> .....	<b>3</b>
<b>Installing the LoadController I System</b> .....	<b>4</b>
Recommended Compressor Locations .....	4
Mounting the Compressor .....	4
Mounting the Dash Panel .....	5
Wiring the Electrical Connections .....	5
Installing the Air Line .....	6
Inflation Control .....	7
Operating Instructions .....	7
Troubleshooting .....	7

# Introduction

The purpose of this publication is to assist with the installation, maintenance and troubleshooting of the LoadController I system.

It is important to read and understand the entire installation guide before beginning installation or performing any maintenance, service or repair. The information here includes a hardware list, tool list, step-by-step installation information, maintenance guidelines and operating tips.

Air Lift Company reserves the right to make changes and improvements to its products and publications at any time. For the latest version of this manual, contact Air Lift Company at (800) 248-0892 or visit our website at [www.airliftcompany.com](http://www.airliftcompany.com).

## IMPORTANT SAFETY NOTICE

The installation of this kit does not alter the Gross Vehicle Weight Rating (GVWR) or payload of the vehicle. Check your vehicle's owner's manual and do not exceed the maximum load listed for your vehicle.

**Gross Vehicle Weight Rating:** The maximum allowable weight of the fully loaded vehicle (including passengers and cargo). This number — along with other weight limits, as well as tire, rim size and inflation pressure data — is shown on the vehicle's Safety Compliance Certification Label.

**Payload:** The combined, maximum allowable weight of cargo and passengers that the truck is designed to carry. Payload is GVWR minus the Base Curb Weight.

## NOTATION EXPLANATION

Hazard notations appear in various locations in this publication. Information which is highlighted by one of these notations must be observed to help minimize risk of personal injury or possible improper installation which may render the vehicle unsafe. Notes are used to help emphasize areas of procedural importance and provide helpful suggestions. The following definitions explain the use of these notations as they appear throughout this guide.

 **DANGER**

INDICATES IMMEDIATE HAZARDS WHICH WILL RESULT IN SEVERE PERSONAL INJURY OR DEATH.

 **WARNING**

INDICATES HAZARDS OR UNSAFE PRACTICES WHICH COULD RESULT IN SEVERE PERSONAL INJURY OR DEATH.

 **CAUTION**

INDICATES HAZARDS OR UNSAFE PRACTICES WHICH COULD RESULT IN DAMAGE TO THE MACHINE OR MINOR PERSONAL INJURY.

---

## NOTE

*Indicates a procedure, practice or hint which is important to highlight.*

---

# Installation Diagram

## NOTES

*This installation should be done after the Air Spring kit has been installed.*

*All preassembled gauge panels have been 100% leak and function tested. Do not attempt to tighten, loosen, or adjust any fittings or connections. This will likely cause a leak or malfunction and void the warranty.*

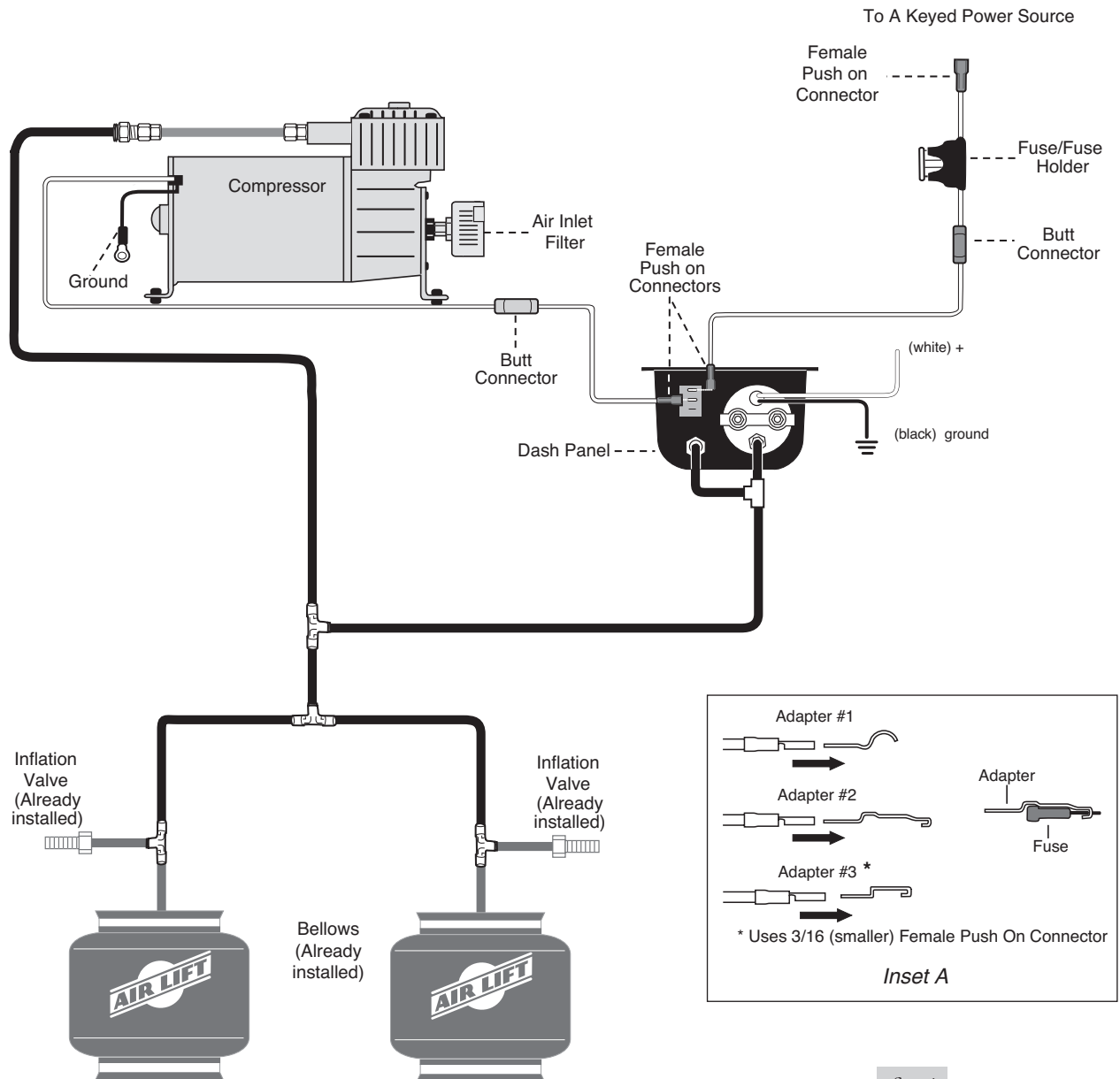

fig. 1

# Installing the LoadController I System

## RECOMMENDED COMPRESSOR LOCATIONS

### Important

LOCATE COMPRESSOR IN DRY, PROTECTED AREA ON VEHICLE.  
DIRECT SPLASH OR EXCESSIVE MOISTURE CAN DAMAGE  
THE COMPRESSOR AND CAUSE SYSTEM FAILURE.

Disclaimer: If you choose to mount the compressor outside the vehicle please keep in mind the compressor body must be shielded from direct splash and the intake should be snorkeled inside the vehicle. If the compressor does not include a remote mount air filter or if mounting the compressor outside the vehicle, make sure to orient the compressor intake filter so that all moisture can easily drain.

#### Please also remember...

- To avoid high heat environments
- To avoid mounting the compressor under the hood.
- To check to be sure the compressor harness #2 will reach the compressor and connect to harness #1.

The compressor can be mounted in any position — vertical, upside down, sideways, etc. (please refer to the instruction manual).

## MOUNTING THE COMPRESSOR

1. Select a rigid convenient mounting location on the frame or in a storage area. The location selected should shield the compressor from the elements.

### CAUTION

BE CAREFUL TO SHIELD THE COMPRESSOR FROM HEAT SOURCES. DO NOT MOUNT THE COMPRESSOR IN THE ENGINE COMPARTMENT. DOING SO CAN CAUSE PREMATURE FAILURE TO THE COMPRESSOR.

2. Using the mounting holes on the compressor legs as a guide, mark the mounting hole locations.
3. Remove the compressor and center punch and drill four  $13/64$ " diameter holes.
4. Use the supplied screws and nuts to mount the compressor (Figure 2).

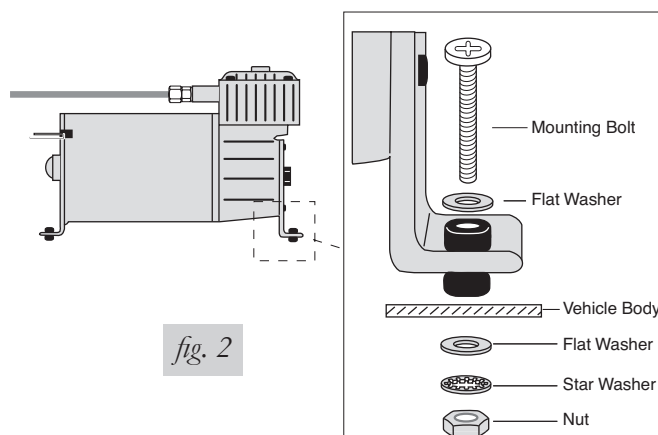

5. Attach the air filter to the inlet port at the back of the compressor (Figure 3).

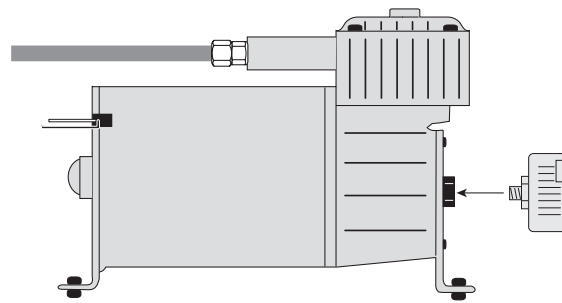

fig. 3

6. Install the fitting into the pressure port side of the leader hose (Figure 4).

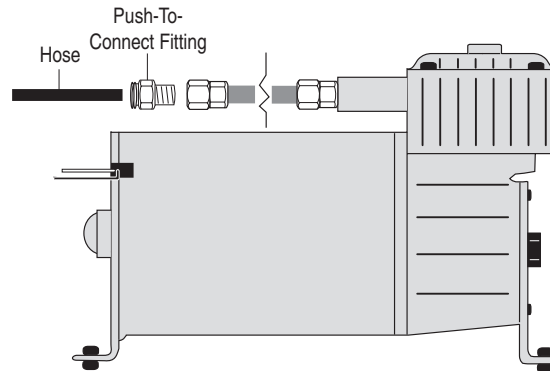

fig. 4

## MOUNTING THE DASH PANEL

1. Select a convenient, sturdy mounting location for the gauge panel.
2. Using the gauge panel mounting bracket as a template, position the gauge panel to the mounting surface.
3. Secure with two self-tapping screws.

## WIRING THE ELECTRICAL CONNECTIONS

1. Install the yellow ring terminal to the compressor motor ground (black) wire. Select a good ground location, and attach the ring terminal with the self-tapping screw provided.
2. Determine the length of supplied (red) wire required to connect the dash panel to the compressor.
3. Connect the (red) wire from the panel to the (red) wire on the compressor using a blue butt connector (Figure 1). Connect the other end of the wire to the push switch using the blue  $\frac{3}{16}$  female push on connector. With your thumb against the front side of the switch, push the connector onto one of the terminals on the back of the ON/OFF switch on the gauge panel
4. Install the 30 amp fuse and fuse holder assembly. At one end attach a female push on connector and the other end a blue butt connector. Connect the fuse assembly to the accessory circuit in the fuse block. Use a test light to determine which open terminal, (accessory, etc.) works only when the ignition is in the on or accessory position. **NOTE: Connect the adapter to the HOT side of the fuse (use a test light to determine).** Connection to the fuse terminal will depend on what type of fuse your vehicle uses. If the vehicle uses the barrel type fuse, use adapter #1. If the vehicle uses the standard spade type fuses, use adapter #2. Many late model vehicles use a smaller spade type fuse which requires adapter #3. See Inset A on the first page.
5. Determine the length of supplied (red) wire required to connect the dash panel to the fuse assembly. Cut and crimp the wire into the butt connector (Fig. 1). Connect the other end of the wire to the push switch using the blue  $\frac{3}{16}$  female push on connector. With

your thumb against the front side of the switch, push the connector onto the remaining terminal on the back of the ON/OFF switch on the gauge panel.

6. Route the white wire for the illuminated gauge to an accessory power source. Attach the black wire to an adequate ground.

## INSTALLING THE AIR LINE

1. Remove the air pressure from the air springs by taking the core out of the inflation valve, or by using a tire gauge to depress the core to bleed off the air pressure.
2. Use a standard tube cutter, a razor blade, or very sharp knife to cut the air line between the air spring and the inflation valve. A clean square cut will ensure against leaks. Install a tee. Repeat this step for other side (Fig. 5).

Cut off excess air line squarely. Install the air line into the fitting. This is a selflocking fitting. Push and slightly turn the cut end of the air line into the fitting as far as it will go. You will hear or feel a definite click when the air line is seated. Air line should go in  $\frac{9}{16}$ ". The air line is now installed.

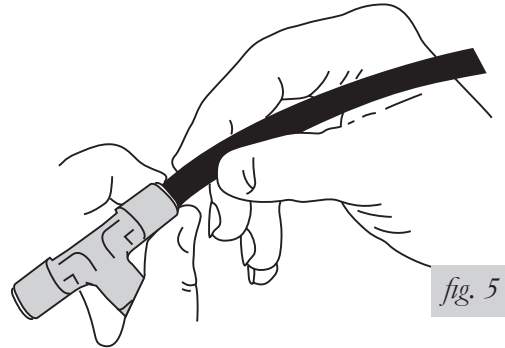

3. Route air line between the two tees and connect to the last opening in each tee.

### NOTE

*Keep air line away from heat (exhaust system, etc.) and moving chassis components. Secure air line to the frame with nylon tie straps provided.*

4. Determine the location of the third tee. Cut the air line between the first two tees and install a third (Figs. 1 & 5).
5. Measure the distance from the open tee to the compressor. Cut the air line to the proper length and install on the last leg of the tee installed between the air springs. Route the air line from the tee to the compressor along the frame and secure with nylon tie straps.
6. Install the air line into the air line fitting previously installed on the compressor (Fig. 4).
7. Determine the closest and easiest area to connect the gauge panel to the air line between the compressor and air springs. Measure the distance between these two points and cut the air line and install the last tee (Figs. 1 & 5).
8. Attach air line to the last leg of this tee and route the air line to the gauge panel. Attach the air line to the panel sliding it onto the barbed fitting on the panel until it fully covers all the barbs.
9. Turn on ignition switch. Push on/off switch and observe pressure increase on the air gauge (Fig. 6). Inflate to maximum recommended pressure. Inspect each connection with a soap and water solution. If a leak is found in the fittings, reduce air pressure to zero and tighten threaded connections or remove air line, cut off one inch and reattach.

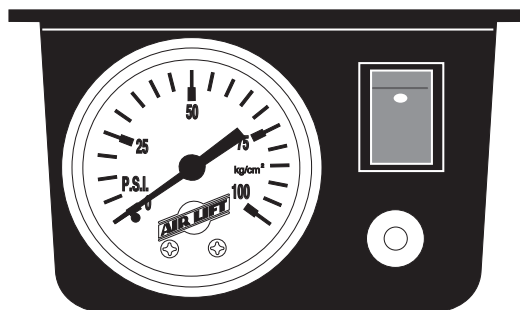

## INFLATION CONTROL

1. Your vehicle is equipped with rear air springs. The following procedure is a guide to assist you in leveling your vehicle to provide the best possible ride and handling.
2. Fill the air springs to maximum recommended pressure. The pressure can be increased from the dash control or the inflation valves located just ahead of the rear wheels. Generally, the vehicle will ride best when the rear springs are slightly arched (if equipped with leaf springs). Start with a higher pressure and decrease in five pound increments to determine the best ride and handling for your particular vehicle. Increases in pressure can be made to compensate for additional load and trailers, etc. Higher pressures can be used when the vehicle is in storage to relieve the leaf springs.

## OPERATING INSTRUCTIONS

1. **IMPORTANT:** Do not exceed the recommended duty cycle of 15% (3 minutes on and 20 minutes off). Not complying with the recommended duty cycle may cause premature failure of the compressor.
2. The air springs should be inflated to the specified air pressure as discussed in the air spring inflation procedure.
3. When ever load and weight distribution change, simply adjust the pressure in the air springs to maintain a level vehicle. The air pressure is manually controlled by the control panel located on the dash.
4. To inflate the air springs and raise the vehicle, depress the switch on the control panel. The compressor will turn on automatically to increase the pressure as indicated on the gauge. Once the desired pressure is reached, release the switch and the compressor will shut-off.
5. To deflate the air springs, depress the button below the on/off switch (Figure 6).

## TROUBLESHOOTING

1. In the event that the compressor stops running, allow the compressor to cool down before running again and provide adequate time for the thermal breaker to reset before trying to start the compressor again.
2. Check the inflation pressure weekly, air spring bellows will permeate (loss of pressure through the rubber wall) at the approximate rate of 3ñ4 p.s.i. per week. Leakage at a higher rate indicates a leak. In order to find a possible leak, inflate the system to the maximum recommended pressure and spray all fittings with soapy water solution.
  - a. Check the inflation valve, including the valve core and air line connections.
  - b. Check the elbow fitting where threaded into the bellows (all threaded connections must have pipe sealant applied) and the air line connection.

### CAUTION

DO NOT EXCEED THE RECOMMENDED DUTY CYCLE OF 15% (3 MINUTES ON, 20 MINUTES OFF). NOT COMPLYING WITH THE RECOMMENDED DUTY CYCLE MAY CAUSE PREMATURE FAILURE OF THE COMPRESSOR.

### CAUTION

DO NOT EXCEED THE VEHICLE MANUFACTURERS MAXIMUM GROSS VEHICLE WEIGHT RATING (GVWR).